



DTL

Damper Technology Ltd

Meadowbank House
Meadowbank Court
Eastwood, Nottingham
NG16 3SL, UNITED KINGDOM
Tel: +44 (0)115 932 4046
Fax: +44 (0)115 932 4047

News Release...

January 2014

DTL Specialise in Dampers for Sulphuric Acid Plant Applications

Global Industrial Damper Supplier, Damper Technology Ltd (DTL) unveils a range of specially engineered dampers for applications involving process gases containing SO₂ / SO₃.



This range of dampers is designed to suit any duct size (typically Ø300mm – Ø3000mm). With SS304H construction they are resistant to corrosion, high temperature (up to 800 Deg C), and creep.

The acid plant dampers have as standard a rigid ledge seal for 99% shutoff and are PED Compliant (as appropriate) for high pressure applications. They have various automation options to suit any process application.

The complex design work for the development of these dampers has been carried out by the experienced engineers at DTL's Head Office in Eastwood, Nottingham, UK and centres around special shaft seals with purged lantern ring and labyrinth arrangement for ZERO LEAKAGE of process gas to the atmosphere. This technology helps to protect the environment and the safety of plant personnel.

DTL have installed these dampers in acid plants in the UK, India, Canada, Jordan and Kazakhstan and are now launching them as a specialist product range in their own right.

DTL was established in 2001 and has a background in the Damper Industry dating back to 1965. Since conception DTL have continued to build on a growing worldwide reputation for quality, innovation, product reliability and cost effectiveness, becoming one of the world leaders in the Damper Market Place.

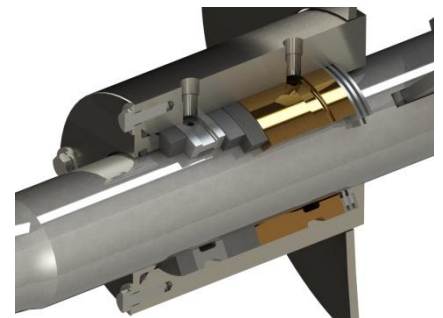

For more information please contact:

Annette Meek, Sales & Marketing for DTL on **0115 721 0815** or email: annette.meek@dampertechnology.com